

# Using PLC Automation for Overhead Line Protection with Automatic Switch

Sagarika Patro<sup>1</sup>, Prativa Barik<sup>2</sup>, Romeo Jena<sup>3</sup> And Subhendu Sahoo<sup>4</sup>

<sup>1</sup>Assistant Professor, Department of electrical engineering and electronics engineering, Aryan Institute of Engineering and Technology, Bhubaneswar

<sup>2</sup>Assistant Professor, Department of electrical engineering and electronics engineering, Raajdhani Engineering College, Bhubaneswar

<sup>3</sup>Assistant Professor, Department of electrical engineering and electronics engineering, Capital Engineering College (CEC), Bhubaneswar

<sup>4</sup>Assistant Professor, Department of electrical engineering and electronics engineering, NM Institute of Engineering & Technology, Bhubaneswar

## Abstract

Transmission lines are the important factor of the power system. Transmission and distribution lines has good contribution in the generating unit and consumers to obtain the continuity of electric supply. Now a day in the transmission lines are ON/OFF are the major and important part in the power system. And also maintenance of the transmission line is also important part in transmission line. In the earlier system for the fault like overloading of the transmission line AB switches are used. The main disadvantage of old AB switch, is they can only operate manually. It requires man power and it has less reliability so, we are introducing automatic AB switch for the protection of overhead line against overload fault it is operated by PLC system. This AB switch can have operated remotely and no man power required on the fault location. It is more reliable and efficient than the old AB switches. The electric power system and advance devices has become a very complicated system because of restructuring and the penetration of distributed generation and storage. In this system the automation link is made possible between the detection and the solution of problem in minimum amount of time.

**Keywords:** Air break switch, Auto line distribution, Alarm indication, Relay Switching, PLC.

## 1 INTRODUCTION

This paper represents the system automatic air break switch which is applied on the overhead line network. This switch is operated by PLC automation system. AB switch is installed on transmission line before the main feeder in substation. This switch is very useful to detect and overcome the fault of overloading on transmission line. When on overload condition is occurs AB switch automatically raised and it open the circuit to protect the line. It after 5 second it again closes the circuit. If the fault is by pass, then it continuous the supply but the fault is not to be overcome then beep the alarm and then we got to know the occurred fault is saviour. This AB switch is very reliable and increase the flexibility of line. Due to PLC automatic it is much easier to access the system and maintain it.

## Objective

- The main objective of our project is to prevent overloading of the transmission line using current sensor.
- There are combinations of a circuit breaker and a relay protection system in a typical fault cleaning system.
- The main parts in protection system are wiring, transducers, auxiliary power supply, switches, circuit breakers, relays and the operating coil of the circuit breaker.
- In normal operating conditions, power system equipment or lines carry nominal voltages and currents which results in an accurate and good operation of the system.

## Problem Definition

- The most common problem is overhead condition which creates fault in operation and it may damage system.
- As fault analysis became important requirements of the electric power system to became more accurate.
- So as to avoid such cases we designed a simple and economical equipment which will give a solution to the above mentioned problems.
- Types of fault may be depending atmospheric parameter and component property.

## Types of fault

There are mainly two types of faults:

1. Symmetrical faults
2. Unsymmetrical faults

### 1. Symmetric fault

A symmetric or balanced fault as name indicate affects each of the three phases equally. Transmission line faults normally, 5% are symmetric.

There are of two types namely

- line to line to line to ground (L-L-L-G)
- line to line to line (L-L-L).

## 2. Asymmetric fault

An asymmetric or unbalanced fault which does not affect each of the three phases. Common types of asymmetric faults, and their cause

There are mainly three types namely

- Line to ground (L-G)
- Line to line (L-L) and
- Double line to ground (LL-G) faults

## TYPES OF FAULT DETECTION

The fault occurring in the power lines and cable can be classified into four main categories : short circuit in the cable or transmission line, short circuit to earth, high resistance to earth and open circuit.

Four method that are mostly used in detecting fault location are described as follow

1. A frame
2. Thumper
3. Time domain reflectometer (TDR)
4. Bridge method

This survey includes the relevant fault models, failure effects or manifestations, fault injection techniques used in developing and validating the safety system, requirements for failure diagnosis, and finally the actual failure diagnosis methods themselves. The development of the algorithm for detecting the faults on the transmission lines has been progressed, especially in recent years. These several decision algorithms have different solutions and techniques. Transmission and distribution lines are vital links between generating units and consumers. They are exposed to atmosphere, hence chances of occurrence of fault in transmission line is very high, which has to be immediately taken care of in order to minimize damage caused by it. In this paper discrete wavelet transform of voltage signals at the two ends of the transmission lines have been analyzed. Transient energies of detail information for two consecutive data windows at fault are used for analysis. Four-layer feed forward back propagation neural networks are designed to classify and locate the fault at different single line to ground fault conditions. It is done by automation. Automation of system has become the demand of the day. In fact, most of the system are impossible to be controlled by human being. The main objective of the project is to design and fabricate an automated control system for automatic power grid control controller and relays.

## 2 LITERATURE SURVEY

Below is the literature review on fault detection or overhead in transmission line using different technique by some authors and their main observations:

It is very important to know the effect of series compensation on transmission voltages [1]. If the effect of series compensation on voltages is not known, it will cause various operational problems such as high voltages and low voltages. Series compensate on can cause low and high voltages due to different line loading conditions and the method by which the voltage control is adjusted.

The protection scheme of double circuit transmission line based on artificial neural network (ANN) has been proposed [2]. Three stages are involved in this scheme to detect and classify different types of faults. Data from one end of the double circuit transmission line has been utilized to calculate the wavelet coefficients. The primary protection is provided to entire transmission line by using one end data only. For forward and backward adjacent transmission line, back up protection is provided. This technique improves the first zone reach setting up to 99% of the length of line for protection of transmission line.

Optimal Coordination of Automatic Line Switches for Distribution Systems [3] Author focuses on distribution feeder automation system; protection coordination; underground 4-way automatic line switch This study investigates the coordination time intervals (CTIs) among the protection devices of the duty point of high voltage customers, automatic line switches lateral protection relays, feeder overcurrent protection relays, bus-interconnection overcurrent protection relays, and distribution transformer overcurrent protection relays, so that the entire protection scheme of the distribution systems can be formulated, particularly for the two-level protection scheme below the feeder circuit breaker (FCB).

Multi-Agents for Fault Detection and Reconfiguration of Power Distribution Systems [4] Author introduced system model for fault detection and reconfiguration based on graph theory and mathematical programming. The multi- agent models are simulated in Java Agent.

## 3 BLOCK DIAGRAM

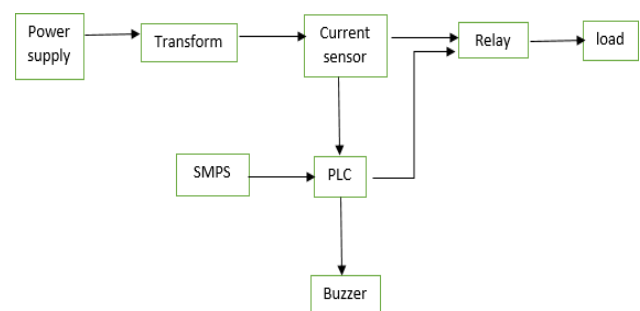

Fig No. 1

#### 4 FLOW

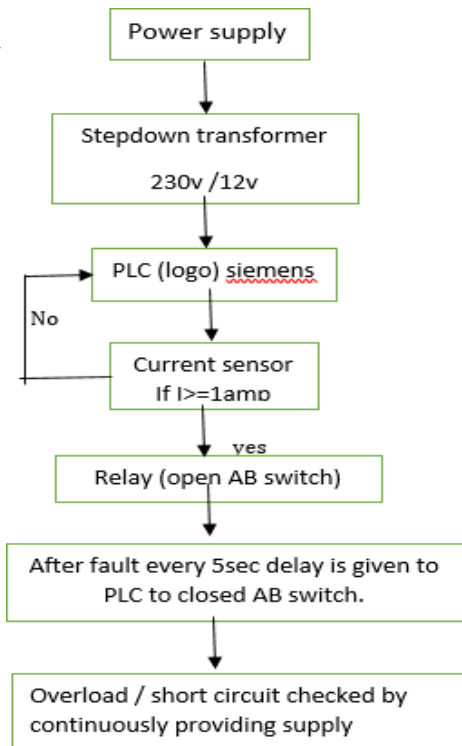

Fig. 2

#### 5 WORKING

As we know, we are using conventional AB Switch for automation by using PLC system and the AB Switch is normally used for the disconnection or to de-energize the supply from the line. The main working of the AB Switch is to disconnect the faulty section without interrupting the whole section or feeder line. So project's main purpose is to disconnect the faulty section using current sensor, which is connected in series with the AB switch which detect the current value as the current value is increases then PLC is gives instruction to circuitry to open or disconnect the AB switch by using mechanism which directed through DC motor and instructed by PLC from Substation and faulty section is easily dis-connected and after 5 second of time PLC gives instruction to circuit to close the open contact for trial of the faulty section if once again fault is detected on line it declared as faulty section.

#### 6 APPLICATION

- On feeder line to disconnect the faulty section. In substation.
- On DP Structure for disconnect the load.
- For load shedding purpose of one of the section.
- In railways and Industries.
- Any other place where AB Switch is used.

#### 7 CONCLUSIONS

The electric energy produced at generating stations is transported over high voltage transmission lines to utilization points. In the early days, electric systems were operated as isolated systems with only point-to-point transmission at voltages that are considered low by today's standards. To improve the power quality of the transmission lines, compensation circuits are integrated. In order to increase the reliability of the system and reinstate the power supply in time, it is of immense important to classify and locate the fault rapidly and to isolate the faulty section precisely.

The choice of a device for fault consideration, best suited to particular field conditions, is not only a technical issue but also an economical one. Unfortunately, most publications on various devices for harmonic suppression are confined to design or to properties of particular devices or methods. Comparative studies on them are generally not available.

#### 8 FUTURE SCOPES

- The modifications to be done in this project are addition of voltage sensor or voltage comparator to detect voltage fault or fluctuation in transmission line.
- This system can be more accurate in term of timing and data recording with the help of PLC.
- We can use GSM module to receive information.
- This system can be used in DC parameter fault analysis.

#### ACKNOWLEDGEMENTS

Sincere thanks to all the anonymous researchers for providing such a useful and helpful opinion, findings, conclusions and recommendations. Also gives immense pleasure to thanks to guide Ms. Rajashree Kadam, HOD Prof. Prof S M More, Principal Prof P S Duggal, and friends for their kind support and guidance.

#### REFERENCES

1. Kincic, S. and Papic, M., "Impact of Series Compensation on the voltage profile of transmission lines," Power and Energy Society General Meeting (PES), pp.1 July, 2013
2. Yadav, A. and Swetapadma, A., "Improved first one reach setting of artificial neural network based directional relay for protection of double circuit transmission lines" IET Generation, Transmission and Distribution., vol. 8, Issue 3, pp. 373 388, 2014
3. Ming-Ta Yang and Jyh-Cherng Gu "Optimal Coordination of Automatic Line Switches for

Distribution Systems" IEEE 2012, 5, 1150-1174;  
doi:10.3390/en5041150.

4. K. Nareshkumar "Application of Multi-Agents for Fault Detection and Reconfiguration of Power Distribution System" IEEE 2008.
5. Abhishek B. Sharma, Haifeng Chen, Min Ding, Kenji Yoshihira "Detection and Localization in Distributed Systems using Invariant Relationships" 2013 IEEE.
6. E. Kallauer "Detection of High Impedance Faults Power Technologies" EPRI Final Report EL-2413 June 1982 Inc.
7. Prof. M. S. Sujatha and Dr. M Vijay Kumar "On-line Monitoring and Analysis of Fault in Transmission and Distribution Line Using GSM Technique" 30th November 2011 IEEE. Vol. 33 No.2
8. "Upper Bounding Fault Coverage by Structural Analysis and Signal Monitoring" Soumitra Bose and Vijay Gangaram Auburn University, 2006 IEEE.
9. Sudhakar M. Reddy "A Test Generation Procedure for Avoiding the Detection of Functionally Redundant
10. Reference book: switching in electrical and distribution transmission system. electrical power transmission system engineering analysis and design.
11. [www.google.com](http://www.google.com)
12. <https://m.indiamart.com>
13. [www.electrical4u.com](http://www.electrical4u.com)
14. [www.dgvcl.com](http://www.dgvcl.com)
15. [www.electricaltechnology.org](http://www.electricaltechnology.org)
16. Wikipedia
17. Reference by MECB officer (Mr. Rajendra pingale)